



Managing Challenging Sampling Environments

How to Handle Active Compounds, Moisture, and Corrosion with Inert Coatings



E-book #3 of 4 in

The Ultimate Guide to Reliable Sampling with SilcoTek® Inert Coatings

Table of Contents

1. Introduction.....	3
2. Hydrophobic Coatings Improve Analytical Systems.....	4
3. Managing Sulfur - Reliable Results without Adsorption.....	7
4. Sampling Mercury and Ammonia.....	10
5. Using Inert Coatings in High Temperature Stack Gas Applications.....	15
6. What about Corrosion? How to Prevent and Remove Rust from Analytical Flow Paths.....	19
7. Conclusion.....	22



1. Introduction

SilcoTek® became a coatings company because we have a passion for helping people and businesses conquer their most difficult material challenges. We help our customers improve analytical results, improve yield and efficiency, and to develop innovations that push the scientific and industrial world forward.



Why Should I Read This E-book?

Because you'll learn how to prevent common sampling and analytical problems and learn ways to save time and money. You will learn how to:

- Improve sample system reliability
- Improve system response and process control
- Reduce troubleshooting
- Get the results you need the first time, every time

Our scientists and engineers are dedicated to teaching the customer how to improve the material performance of their products and processes. Read on and benefit from our over 250 years of analytical experience.

Paul Silvis, Head Coach

2. Hydrophobic Coatings Improve Analytical Systems



A single drop of water may appear to be harmless, but it can have a huge impact on the durability and performance of analytical and process monitoring systems. Moisture condensation in sample delivery, analytical GC columns, and process systems can cause corrosion as well as loss of sulfurs and reactive compounds.

Even trace amounts of water in process sample and transport systems can have a major impact on product yield and quality in refining, petrochemical, polymer, and semiconductor manufacturing applications, amongst others.

Moisture Impact on Sulfur Loss

Test results can be degraded significantly when moisture is present in sample systems. Water droplets in downhole and process sampling systems can lead to artificially low reporting of H₂S content in gas and oil wells and petrochemical feedstock; resulting in system corrosion, low process yield, high processing cost and catalyst damage. A comparison of a dry vs. wet sample cylinder (below) tells the story. A dry sample cylinder retains about 85% of the sample after 14 days of storage. The moisture contaminated sample cylinder (right) retains less than 70% of the sample after 14 days; an 18% reduction in H₂S sensitivity!

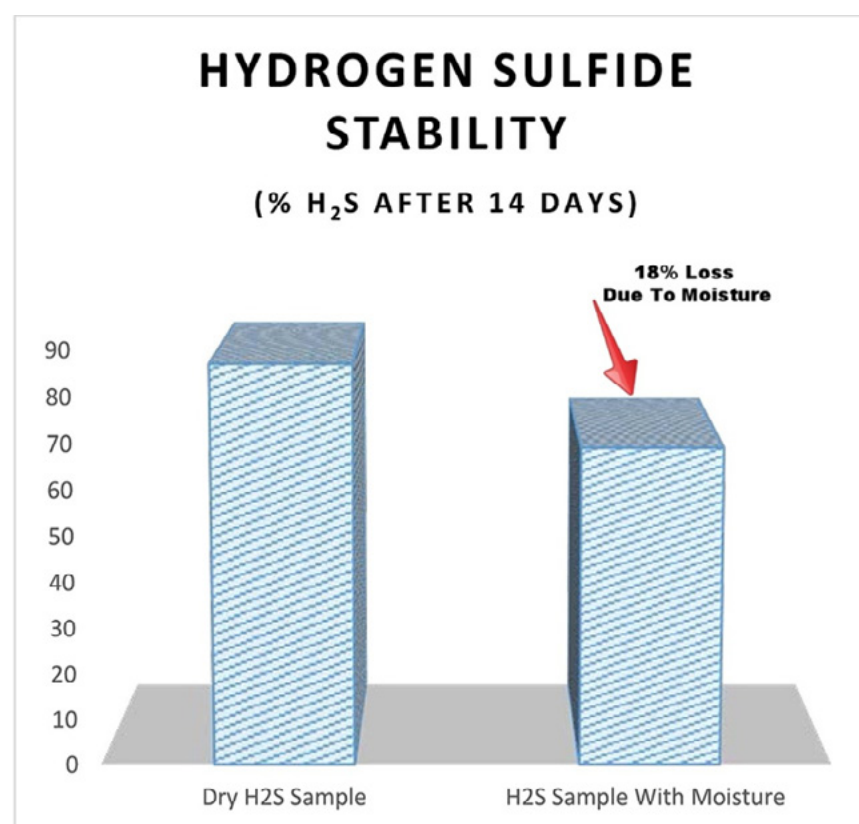

Coatings to Repel Moisture

SilcoTek [hydrophobic coatings](#) repel water, dry quickly and don't retain moisture, resulting in greater sensitivity and durability in sample transfer and analytical systems.

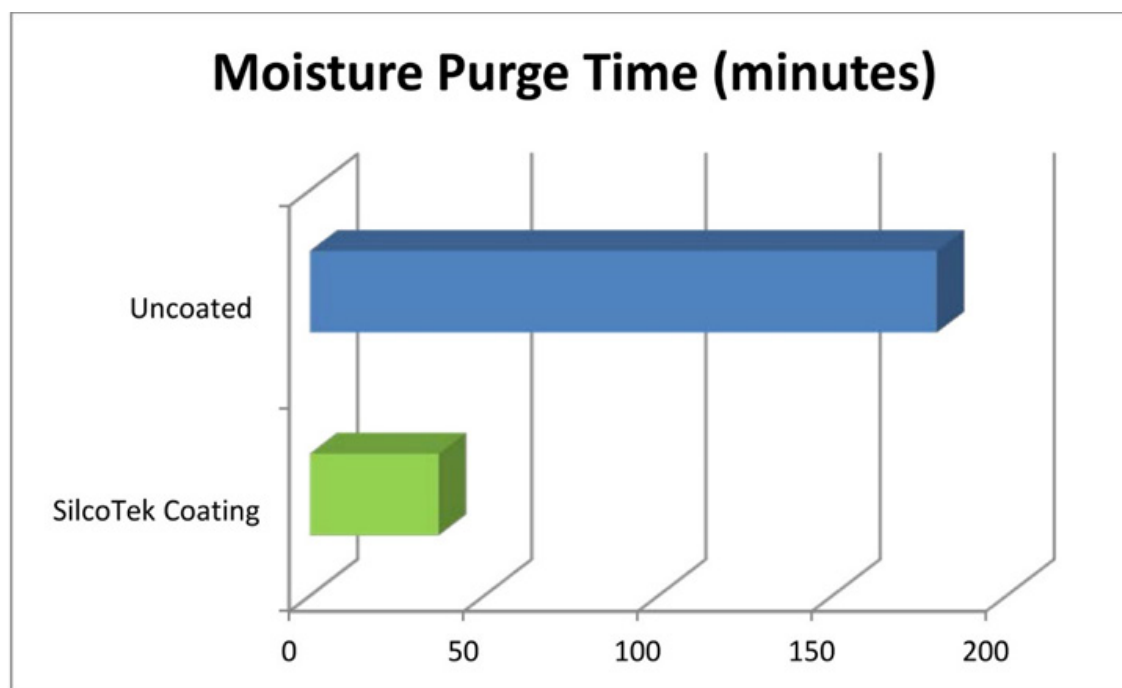

SilcoTek's inert, high temperature barrier coatings prevent surface interaction between critical flow path surfaces and your product. Dursan[®] improves moisture repelling properties of stainless steel, glass, and ceramic surfaces by 60% or more when compared to uncoated stainless steel. Comparative contact angle tests show stainless steel demonstrates limited moisture repelling properties with a low 20 degree contact angle. Moisture will wet the surface and "stick" in surface irregularities, causing analyte solvation and test errors. Dursan-coated surfaces exhibit exceptional moisture resistance and provide a 100+ degree contact angle. Dursan-coated surfaces prevent moisture contamination and solvation.

Contact Angle Comparison

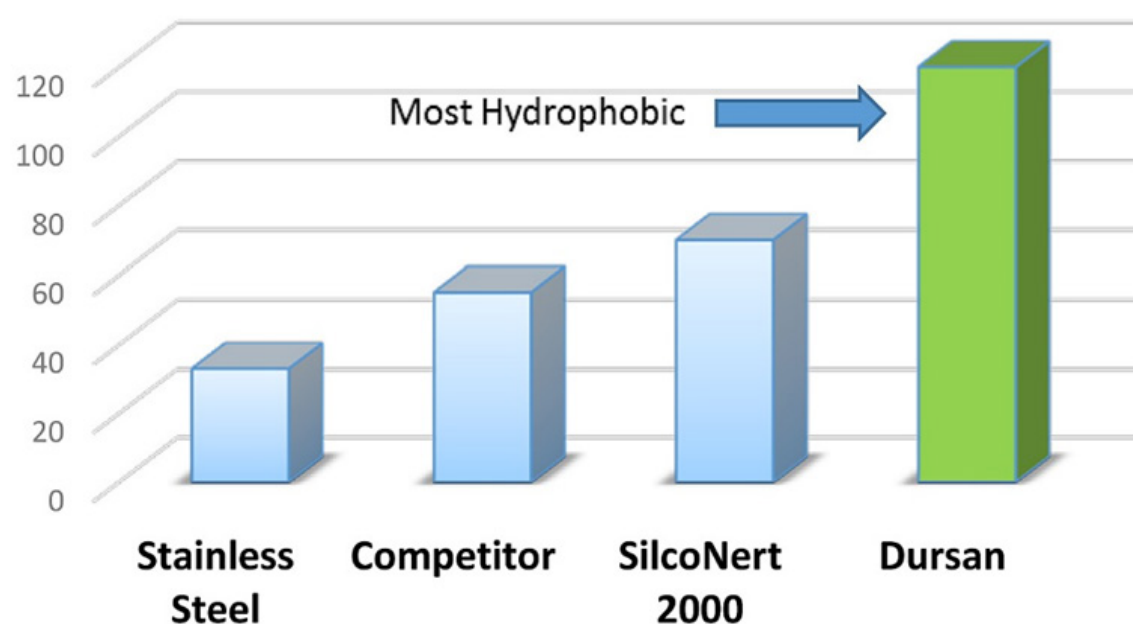

Coatings benefits include:

- Less water accumulation and retention in analytical systems.
- Faster system purge. Water is repelled so it's easily removed.
- Fast recovery. Fast-drying surface allows for quicker response.

SilcoTek's most moisture-repelling CVD coating, [Dursan®](#), is a durable high-tolerance coating that can be applied to complex wetted flow paths without changing part functionality. Dursan improves component performance without requiring design, material, or mechanical changes.

Maximize Hydrophobicity

To improve hydrophobicity in analytical systems, coat the entire flow path. Don't forget to also treat the purge gas system and calibration flow path.



- Regulators
- Filters
- Fittings
- Analytical components
- Valves
- Probes
- Tubing
- Moisture sensors

3. Managing Sulfur - Reliable Results without Adsorption



How important is managing sulfur in process analytical systems? Here's an example of how a sulfur sampling failure can impact the performance of a refinery:

A Texas refinery suspected higher than normal H_2S in their flare gas, a potential violation under [flare and fence line monitoring regulations](#). Yet the H_2S sampling system showed emissions were within spec. But why was the low-level calibration showing no H_2S ? The stainless steel heat trace tubing was properly set at 200 °C. Could the stainless steel tubing in the heat trace line be adsorbing the sulfur, or is something else going on?

Tests at ambient temperature comparing [SilcoNert® 2000](#)-coated heat trace tubing vs. uncoated stainless steel tubing showed significant adsorption of the H_2S onto the uncoated stainless steel. The graph below shows a relative percent loss of sulfur on stainless steel and SilcoNert-coated surfaces. Over time, virtually 100% of the sample is lost due to adsorption for a stainless steel surface. The SilcoNert surface shows virtually no loss of sulfur.

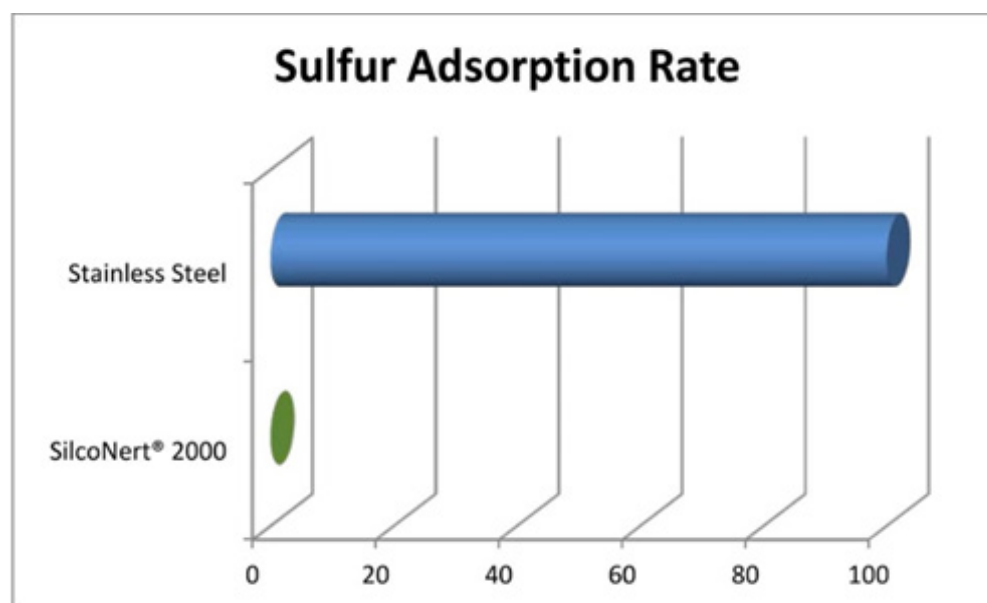

The adsorption caused a significant delay in results but did not account for all the loss.³ The paper "[Do's and Don'ts in the Analysis of Sulfur](#)" by Biela¹ and Reese² confirmed refinery's suspicions. The hot stainless steel in the heat trace tubing was causing decomposition of the H₂S.

The papers demonstrated how H₂S will decompose on hot stainless steel.

- Mechanism presented by Reese: Oxidation to SO₂ above 100 °C in contact with stainless steel – assisted by the metal oxides which can be cleaved of oxygen
- Biela demonstrated complete loss of H₂S, 100ppb, at temperatures above 100 °C on stainless steel.
- Biela also demonstrated that when an inert coating is applied over stainless steel, H₂S loss is eliminated. The testing was conducted from 50 °C to 225 °C.

Comparative testing exemplifies the extent of H₂S adsorption and decomposition on stainless steel. After only 1 hour nearly 100% of the sample was lost due to reactivity of the stainless steel, aluminum, or carbon steel surface. A [December, 2002 study by American Mobile Research, Inc.](#) compared the surface inertness of various sample cylinder surfaces used in sulfur sampling in natural gas and natural gas liquids. The study concluded that SilcoNert-lined surfaces exhibited very low sulfur adsorption over 1 hour and 72 hour comparisons.

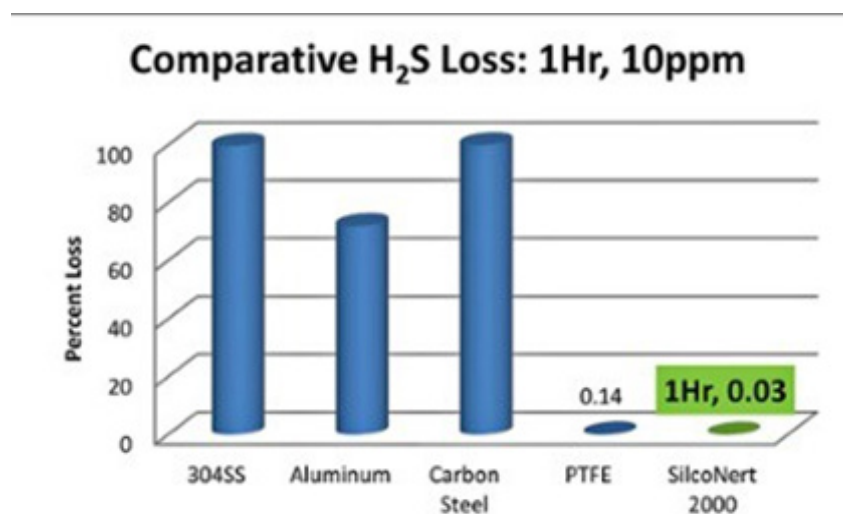

How to Manage Sulfur in Process Analytical Systems

To prevent adsorption and surface reactivity of stainless steel and assure maximum stability in stack and flare monitoring, use SilcoNert[®]-coated flow paths to maintain sample quality, even after 14 days of exposure. The graph below shows repeated sample cylinder tests using low level, 11 part-per-billion, sulfur samples. The results show consistent levels of sulfur throughout the sample period. Inert coatings are an ideal solution to [sample cylinder stability problems](#).

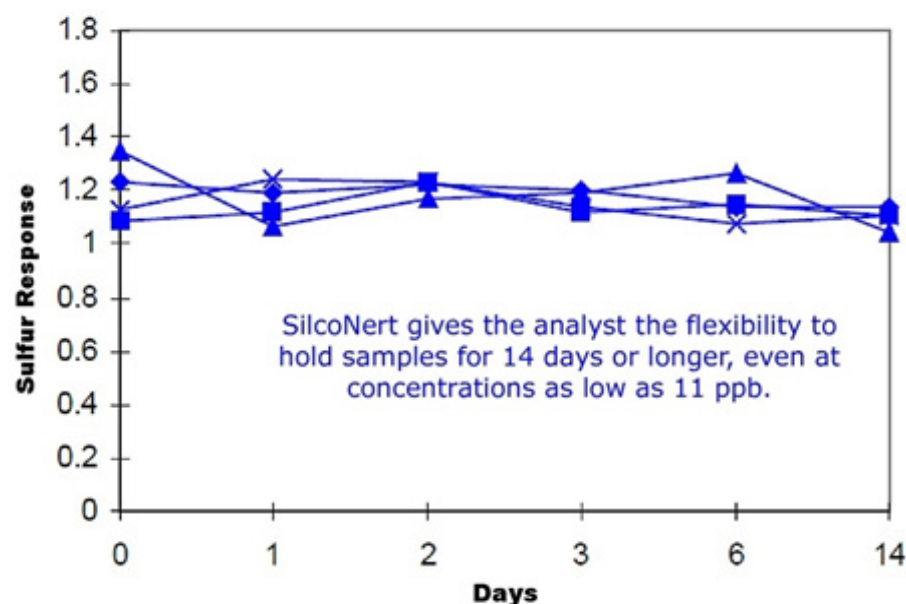

The Solution

The refinery decided to coat the sample flow path with SilcoNert® 2000. After coating the flare sampling pathway, the sulfur response and recovery improved by orders of magnitude, assuring compliance for the refinery. The graph below⁴ compares response time of coated and uncoated surfaces. The SilcoNert-coated surface offers vast response, avoiding delays of 10 minutes or more in emission monitoring systems.

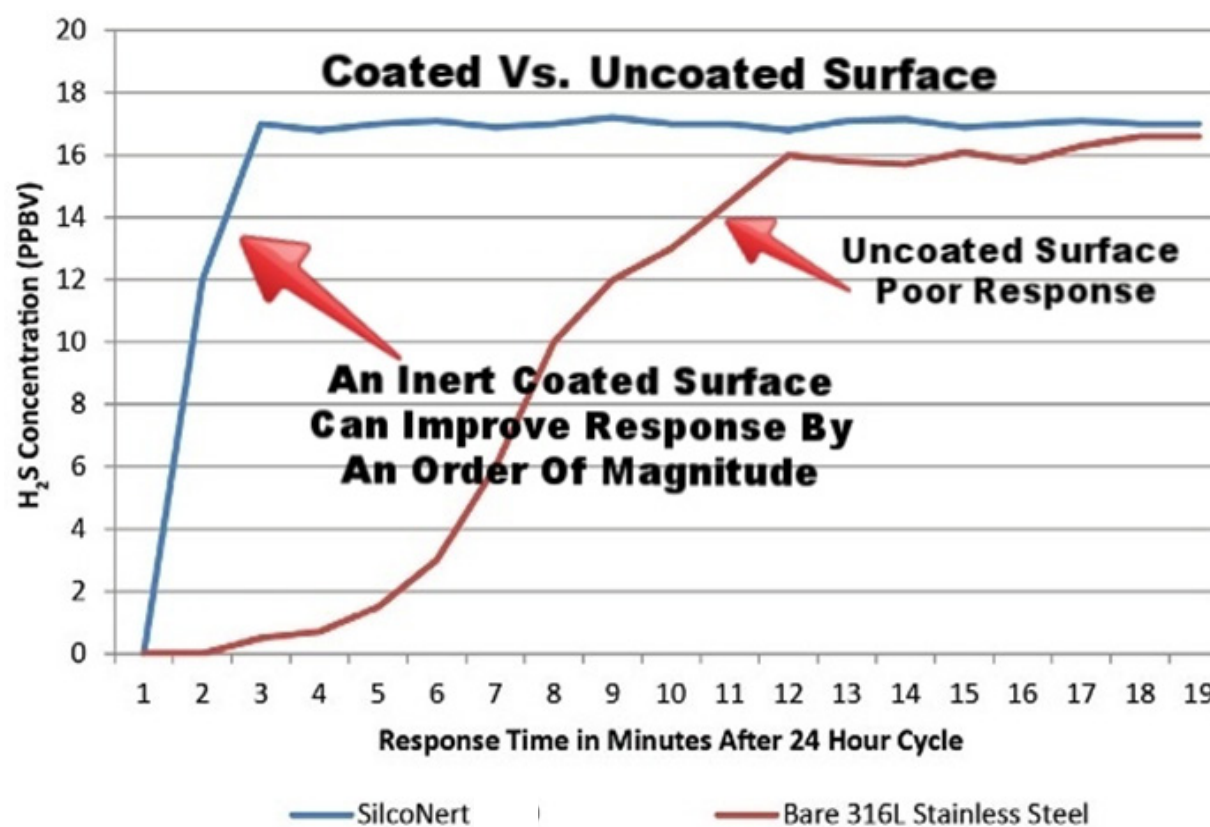

Coat the Entire Sampling Pathway



- Probes
- Fittings
- Heat trace tubing
- Regulators
- Filters

Did you know?

You can purchase inert SilcoTek-coated products through many well-known sampling and analytical component suppliers. Go to our [component and supplier listing page](#) for information about how to purchase inert coated products. You can also [send your analytical and sampling components directly to SilcoTek for coating](#).

1 Biela, B.; et. al. "The Do's and Don'ts in the Analysis of Sulfur for Polyolefin Producers"; Gulf Coast Conference, Galveston, TX, Paper 081 (2003)

2 Reese, G.; Mason, A.; Cuthbert, D., "A Novel Solution for the Analysis of Speciated Sulfurs and Nitriles in Various Hydrocarbon Streams"; Gulf Coast Conference, Galveston, TX, Paper 36 (2014)

3 Data and image courtesy of Shell Research and Technology Centre, Amsterdam; O'Brien Analytical, St. Louis Mo. Report ASA/2-2003-11-2, 15 March 2004.

4 Data courtesy of Concoa

4. Sampling Mercury and Ammonia



[Continuous emission monitoring systems](#) (CEMS) and sorbent tube samplers can be degraded or compromised by the loss of mercury species and ammonia on reactive sampling surfaces. Reactions and adsorption on inner surfaces of transfer and monitoring equipment cause significant failures in system reliability. An inert flow path will prevent stainless steel surface interaction with active and reactive compounds during sampling and transfer. Without an inert coating like SilcoNert®, analyzers will produce inconsistent or substandard results, such as:

- Erratic calibration
- Long delays in response
- Inaccurate results
- False positive or false negative readings
- Lost mercury in sample storage equipment

SilcoNert Improves System Response

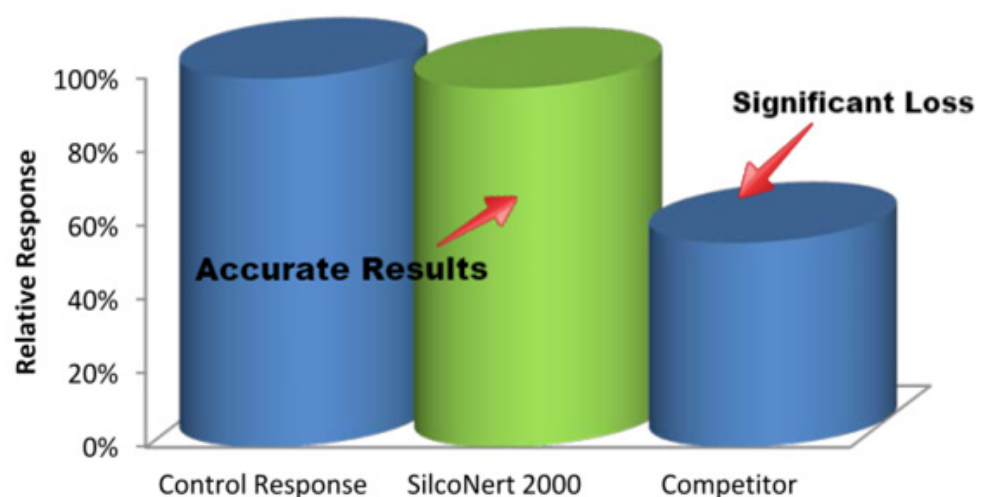

Comparative Mercury Tests

Comparative data demonstrates that SilcoNert 2000-treated stainless steel surfaces provide superior [mercury compatibility \(inertness\) performance](#) compared to untreated stainless steel. Results show that SilcoNert 2000 treatment is ideal for components and tubing exposed to mercury samples in CEMS and sorbent tube mercury sampling systems.²

Stability data (below) compares SilcoNert® 2000-treated 304 grade stainless steel gas sampling cylinders (Swagelok®, Solon OH) and untreated sample cylinders. Each cylinder was filled with 8 ug/m³ of elemental mercury (approximately 1 part per million) (Spectra Gases, Alpha NJ). The mercury in each cylinder was measured over time to determine the changes in concentration. The SilcoNert-treated sample cylinders showed minimal loss, while the uncoated cylinders lost 80% of the sample over the test period.

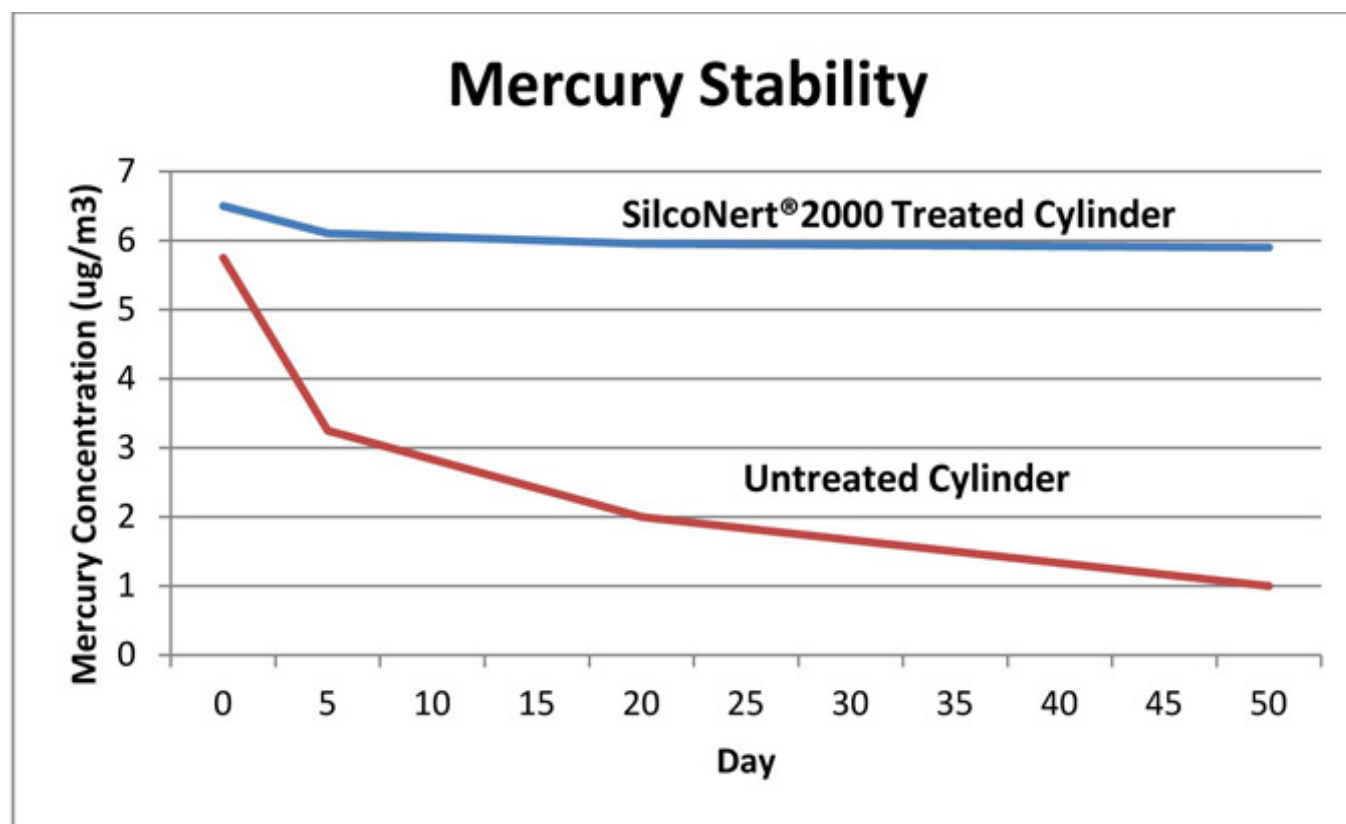

Optimize the Flow Path

Application of SilcoNert® 2000 to all of the components of a stack or continuous emission monitoring system will greatly improve analytical reliability and sensitivity, and will be needed as regulations are promulgated and emission quotas are enforced. Wetted flow paths should be coated to prevent exposure of the sample to reactive stainless steel surfaces.

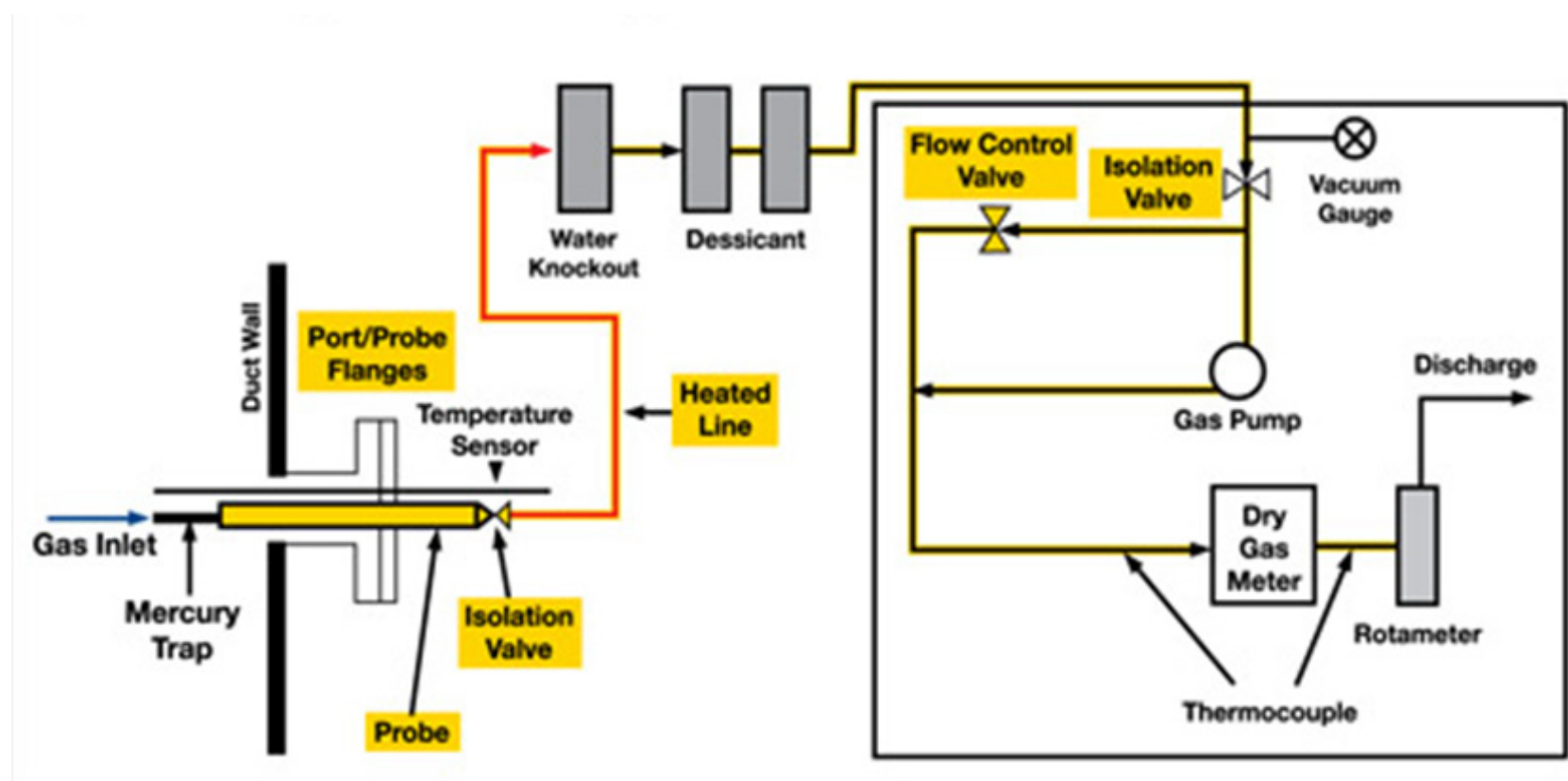

Typical stack sampling train. SilcoTek®-coated flow paths will prevent adsorption of mercury, ammonia, and sulfur compounds, assuring reliable compliance monitoring.

Comparative Ammonia Testing

Trace ammonia sampling in automotive, refinery, and industrial applications can be tedious at best and impossible under worst case conditions. If you've ever experienced progressively erratic and irrelevant results when testing for trace ammonia, Bertrand S. Lanher, PhD. with Sensors, Inc. may have an answer to your problem. [A recent study by Dr. Lanher](#) compared stainless steel, PTFE, and SilcoNert® 2000-coated tubing (noted as Sulfinert) for relative inertness, adsorption, and retention of trace level NH₃.

Dr. Lanher's test results (below) show that a relatively short 3 meter length of uncoated transfer tubing can be adsorptive and can result in significant delay in response and test errors.¹

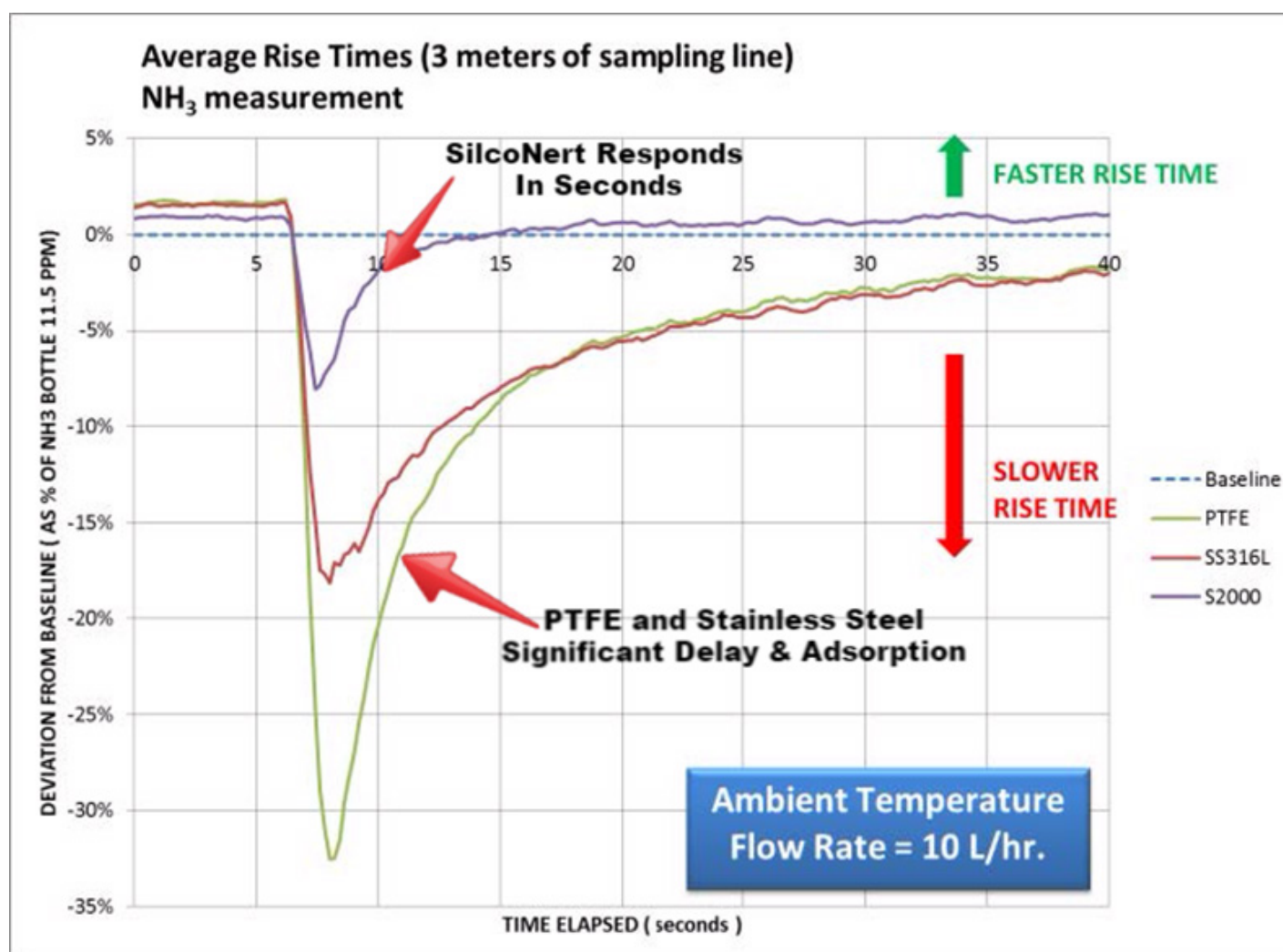

In fact, test errors can be significant; initial NH₃ signal rise time results show major differences:

- 32% less response with a PTFE tubing flow path
- 18% less with a stainless steel flow path
- 8% less with SilcoNert-treated flow path

The study concludes:

“Results unequivocally show that, at equivalent operating conditions of temperature, pressure and flow rate, Sulfinert®-coated SS316L sampling lines offer the fastest response and recovery rates for the measurement of NH₃ using an extractive spectrophotometric method when compared to PTFE and standard SS316L sampling lines.”

Why Response Error Matters

Reactive flow paths like PTFE and stainless steel will hold onto an ammonia sample, causing delayed readings or artificially low readings. As the NH_3 accumulates in the system flow path, it will eventually desorb or leach into the sample stream, resulting in high readings. The back-and-forth adsorption and desorption ultimately makes testing less and less relevant to real world conditions. At minimum, a reactive flow path will reduce test efficiency while the analyst struggles to recalibrate or purge the flow path. At worst, a reactive flow path will skew test results, jeopardizing regulatory compliance or may lead to process stream contamination or reduced yield.

This can be especially important for [refinery and process continuous testing systems](#) and [automotive emissions testing](#).

Fast response means less chance of a cumulative build-up of reactive compounds in the system and fewer test errors. The key to fast response? A surface that does not retain or adsorb the analyte. The graph below shows SilcoNert[®] does not adsorb the NH_3 analyte, so there's little resulting desorption and disruption to analytical results.

SilcoNert's response time to baseline is the shortest of the 3 surfaces compared:

- Stainless steel: 33 seconds
- PTFE: 18 seconds
- SilcoNert 2000-coated stainless steel: 9 seconds
- Baseline: 6 seconds¹

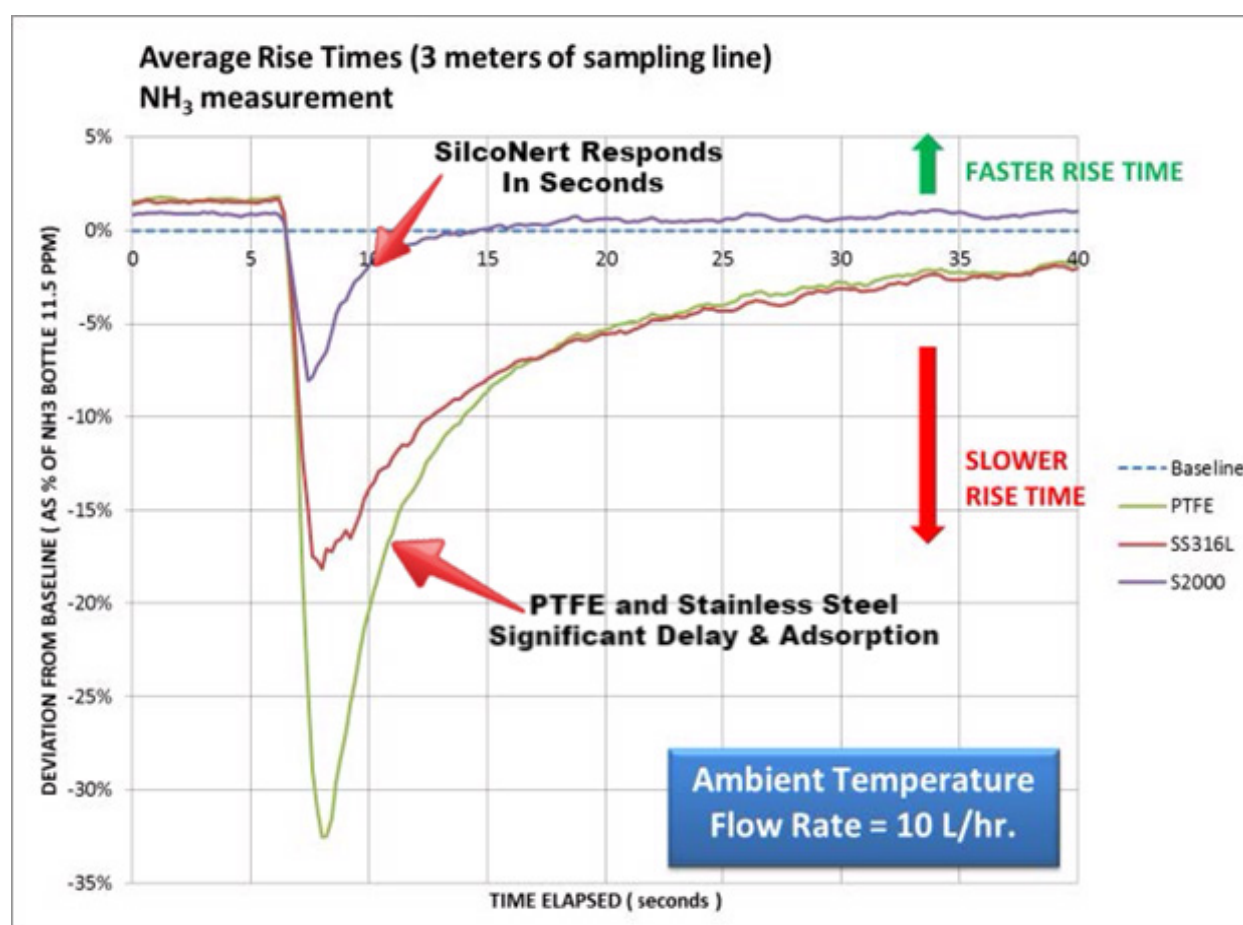

Coat the Flow Path

What's the fix for ammonia and mercury test problems? SilcoNert[®]-coat the entire flow path. A short piece of tubing may not seem like a test killer, but the results prove that seemingly little things like an inert surface in the flow path can make the difference between garbage results and consistent, robust results. Other components you should coat are:

- **Fritted filters:** Each frit has a relatively huge surface area. Not coating frits will lead to performance issues related to high sample adsorption.
- **Regulators:** Although less surface area than frits, regulators too can retain NH_3 and Hg, distorting calibration gas integrity and leading to calibration errors.
- **Valves and fittings:** As detection limits move from part-per-million to part-per-billion sensitivity, even small fittings and valves can retain sample compounds and distort results.
- **Sample cylinders:** Internal surfaces of sample cylinders are quite rough, creating ideal conditions for unwanted adsorption of ammonia and mercury.

1. Image and data credit: Bertrand S. Lanher, PhD., Sensors, Inc. Saline, MI – USA, “INFLUENCE OF MATERIAL AND TEMPERATURE OF SAMPLING LINES OPERATED UNDER HIGH VACUUM ON THE RESPONSE OF EXTRACTIVE SPECTROMETERS APPLIED TO THE REAL-TIME MEASUREMENT OF TRACE AMOUNTS OF AMMONIA.”; SEMTECH LASAR, Technology White Paper Series.

2. Gary Barone, David Smith, Luke Patterson SilcoTek Corporation, Bellefonte, PA – USA, “Review of Coatings Used to Improve Reliability and Accuracy of Sulfur, Mercury, Ammonia and NO_x Sampling and Analysis Equipment”, 2015, ISA, Annual Symposium of the Analysis Division”, Galveston, TX – USA.

5. Using Inert Coatings in High Temperature Stack Applications



Customers using our [oxidation resistant](#), [corrosion resistant](#), and [inert coatings](#) in high temperature stack, flare, and process applications (over 450° C) often ask if the coatings can “take the heat.” Our answer tends to be a bit long winded, but the short answer is yes; our SilcoNert® 1000 and Silcolloy® coatings are able to withstand temperatures over 1000° C, but there’s a condition.

The long answer is: SilcoNert 1000 and Silcolloy can take the heat over 1000 °C and more, but if you’re heating over 450 °C, you’ll need to preheat the part up to or over the maximum temperature in an inert atmosphere to assure the coating integrity.

Why such a long answer? It’s a little complicated, but it all revolves around a phenomenon called carbide precipitation.

Stainless Steel’s Achilles Heel

Stainless steel is a wonderful metal. It’s corrosion resistant, easy to machine and can be made in vast quantities relatively inexpensively. There are issues with stainless steel, however - particularly 300-grade stainless steel.

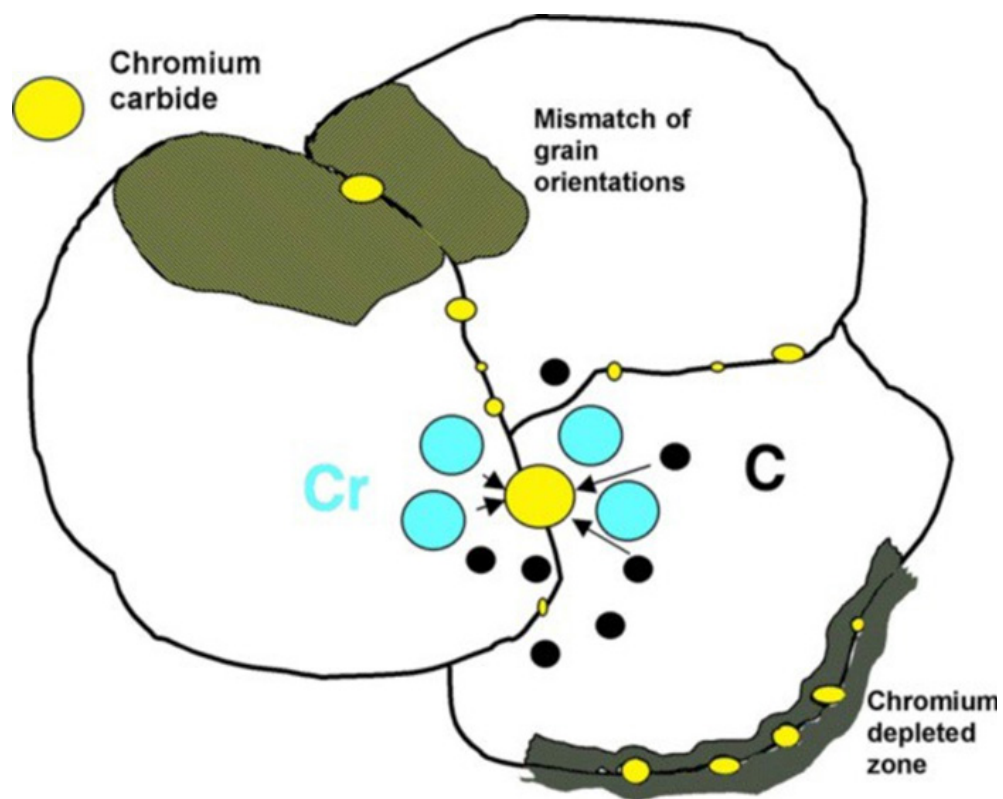

When heated above 500 °C, carbon in the metal grain boundaries of stainless steel will migrate (precipitate) out of the metal to the surface. The overall result is increased susceptibility to corrosion, known as heat sensitization.*

Here's an example of a time-temperature curve showing temperature and time envelopes when 304 stainless steel will lose carbon and become sensitized to corrosive attack.**

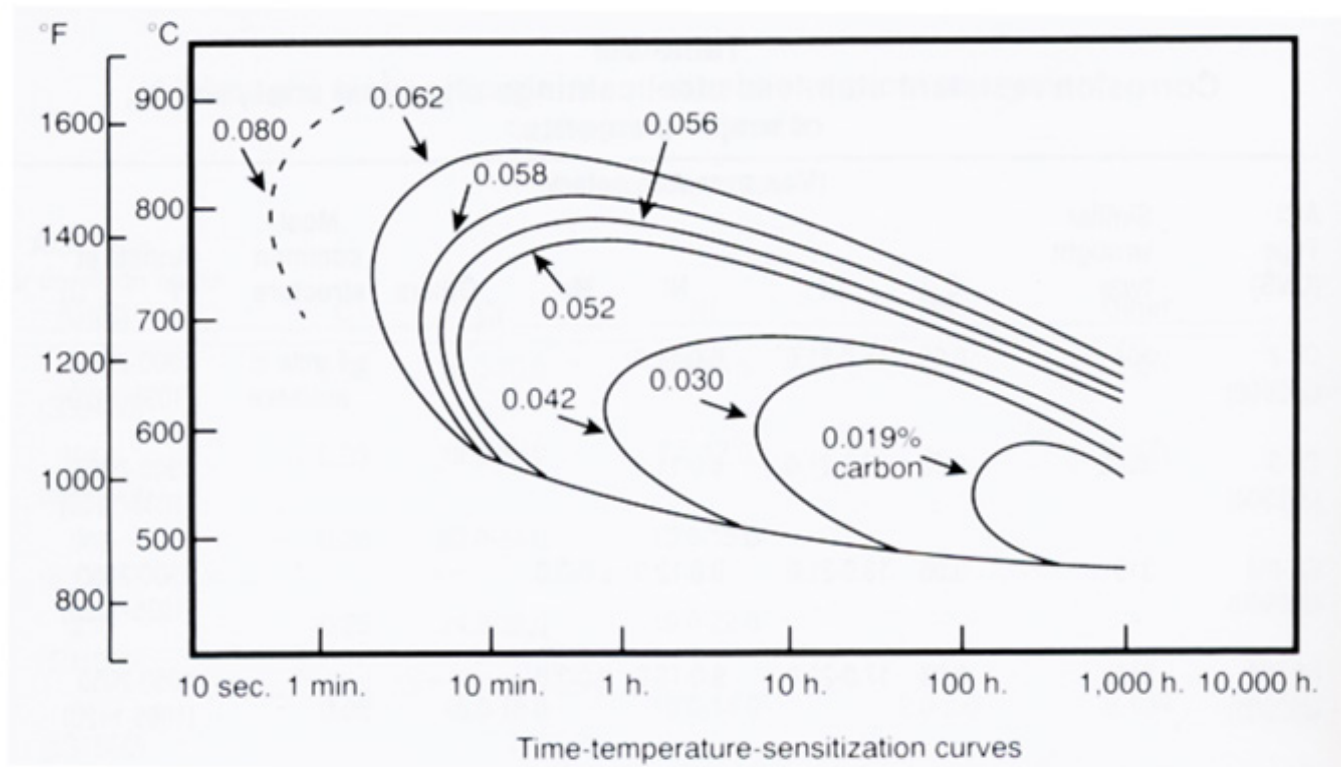

What does Grain Boundary Corrosion have to do with Coating Integrity?

Good question! When the carbon migrates to the stainless steel surface it will displace the coating, resulting in failure. Preheating the part will get all that carbon precipitation over with and prevent the coating from being pushed off the stainless steel surface during high temperature exposure. This will assure proper bonding of an oxidation resistant coating to the surface.

One note of caution, heating the surface may sensitize the part to corrosion. If you're concerned about corrosion in your application, you'll want to consult metallurgy time-temperature curves for your particular alloy and follow recommended heat treatment methods to prevent heat-related corrosion.

When heated above 500 °C, carbon in the metal grain boundaries of stainless steel will migrate (precipitate) out of the metal to the surface. The overall result is increased susceptibility to corrosion, known as heat sensitization.*

To assure a stable high temperature coating, follow these 3 steps:

1. Consult recommended metallurgy guidelines for your alloy.
2. Preheat part to the target temperature per the guidelines (approximately 10 hours should do the trick).
3. Heat in an inert environment to prevent oxidation of the surface.

Oxidation Resistant Coating Benefits

Silcolloy®, a high temperature silicon coating, improves oxidation and corrosion resistance of stainless steel by preventing oxygen from interacting with the stainless steel surface, increasing oxidation resistance by orders of magnitude. The comparative oxidation rate of stainless steel vs. Silcolloy shows that the stainless surface oxidizes at a much faster rate than the coated surface.

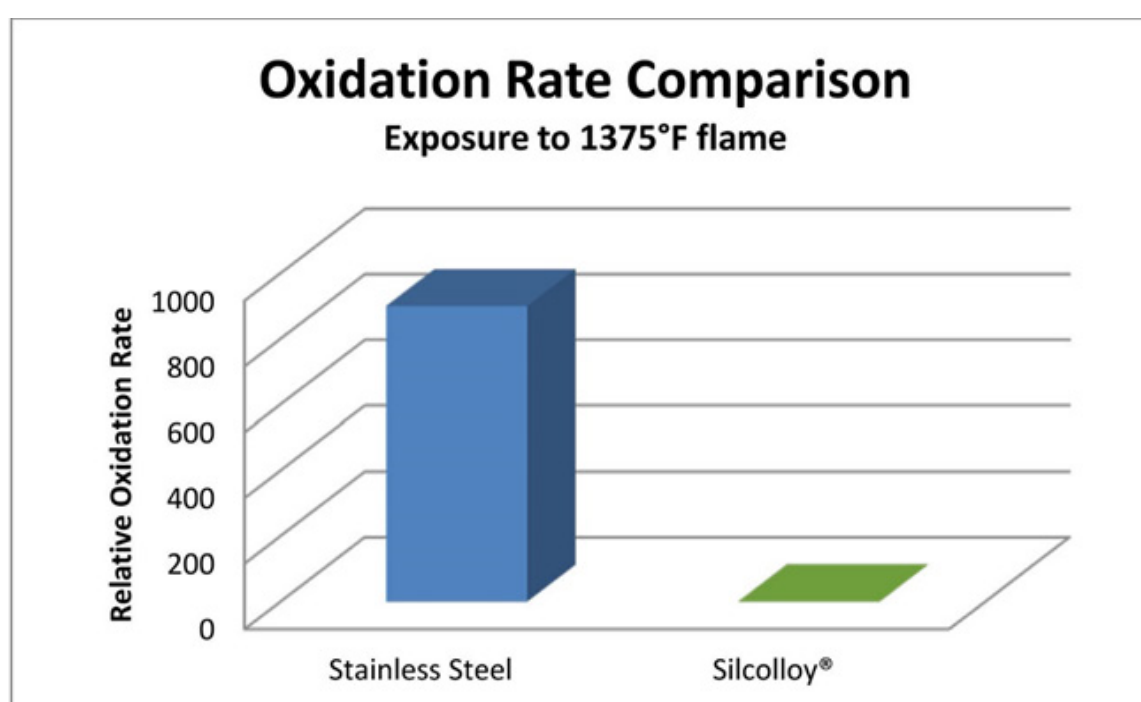

Silcolloy® will maintain a lustrous surface finish even under the most demanding conditions.

- Extend the life of components exposed to high temperatures
- Eliminate contamination from corrosion/oxide formation
- Maintain critical tolerances under high heat conditions
- High temperature coating maintains surface finish, even when exposed to >1000 °C in air
- Eliminate time consuming cleaning/oxide removal

[Watch our video](#) to see how SilcoTek coatings “take the heat.”



SilcoTek's high temperature coatings are used in a diverse range of industries and applications:

- [Stack and flare sampling](#)
- [Fuel delivery and fuel nozzles](#)
- [Fluidized bed reactors](#)
- [Downhole sampling](#)
- [Refining](#)
- [Reactors and research](#)

* Image courtesy of SSIA

** Image courtesy of SSINA

6. What about Corrosion? How to Prevent & Remove Rust from Analytical Flow Paths



Stainless steel is typically specified because of its ability to resist corrosion in a variety of environments. Unfortunately, stainless steel is not fully stain or rust proof; it's just more resistant to corrosion than lower grade steels. Anyone who operates a refinery or offshore facility knows all too well that exposure to high salinity environments such as sea water or exposure to other chlorides such as HCl can remove the stainless steel's native protective layer (chromium oxide) and allow oxidation/corrosion to occur at the substrate.

Silcolloy® and Dursan® coatings are both applied to improve the corrosion resistance of stainless steel and other alloys.

[Read more about SilcoTek's corrosion resistant coating solutions](#)

Preventing Rust

If you're sampling in a corrosive or reactive environment, it makes sense to avoid sample contamination and damage to the sample pathway by coating wetted surfaces with an inert, corrosion resistant barrier coating. SilcoTek's [Dursan coating](#) helps to avoid product contamination and extends the life of process equipment and sample flow paths.

Table I provides the results obtained from ASTM G31 testing. This method is an immersion test for 24 hours in a 6M hydrochloric acid (HCl) (18%) solution at room temperature and pressure. After immersion, differential weighing allows the amount of material loss to be determined. The Dursan-coated surface significantly improves chloride corrosion resistance.

Table I: Weight loss after 24 hour exposure to 6M (18%) HCl

24hr; 6M HCl; 22°C	304 SS	Silicon coated	Dursan coated
MPY (mils-per-year)	389.36	16.31	1.86
Improvement Factor	---	23.9	209.8

Comparing multiple coupon materials, Dursan®-coated 316L stainless steel demonstrates similar performance to super alloys.

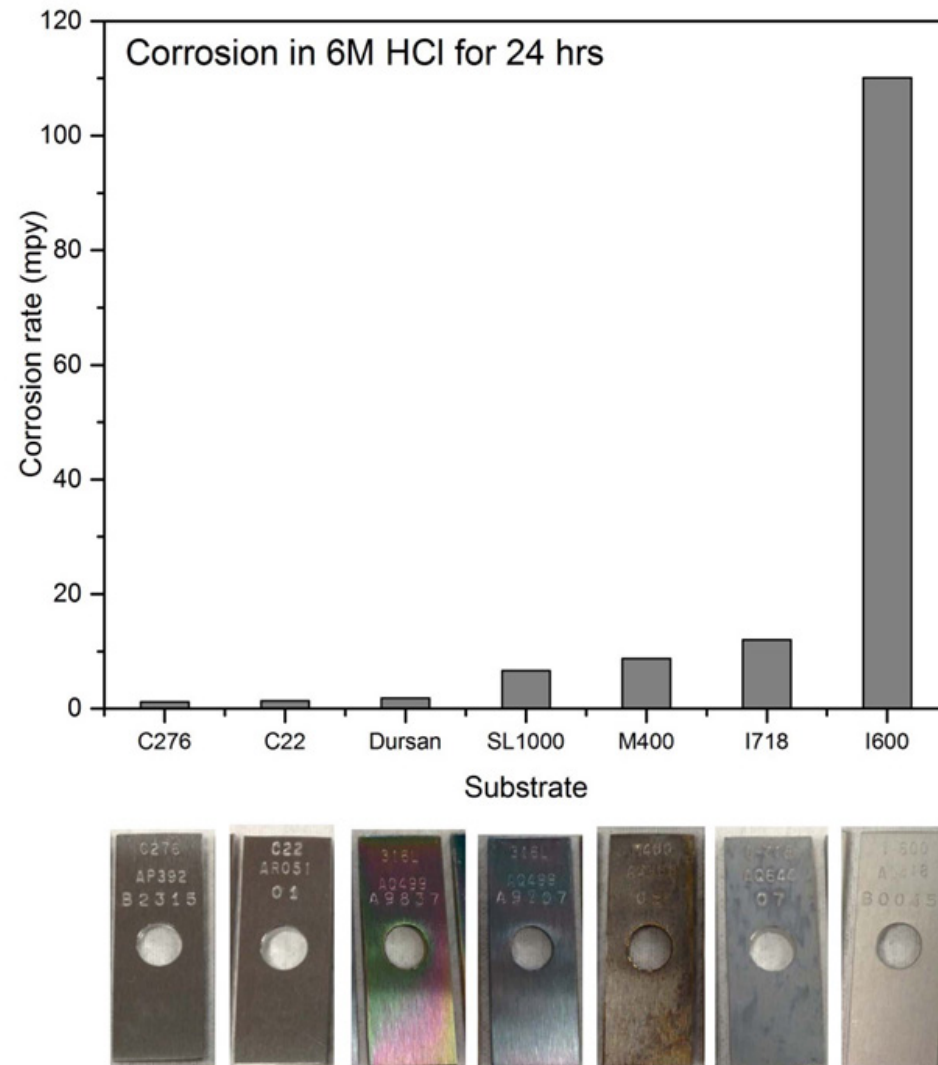

Superior Salt Spray Performance

Salt spray exposure tests show Dursan significantly improves salt corrosion resistance, extending the useful life of 300-series stainless steel from weeks to years.

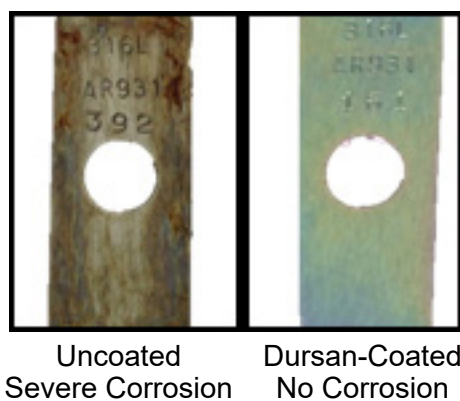

EIS ([Electrochemical Impedance Spectroscopy](#)) data show Dursan remains pinhole free after over 250 days of salt spray exposure. In the experiment below, test coupons are subjected to salt spray for 247 days. The test samples were periodically tested by introducing a voltage between 5 to 50 mV with a range of frequencies. If the resulting data points do not diverge or curve, no additional pin holes were produced.

Stainless steel:
Significant pinholes
leading to corrosive
activity.

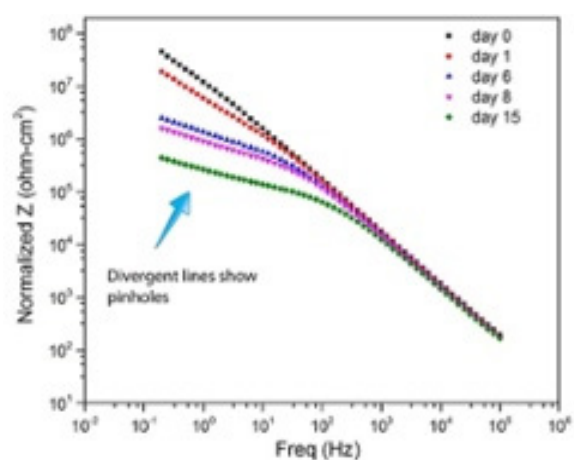

Dursan®:
No pinholes, no
corrosion.

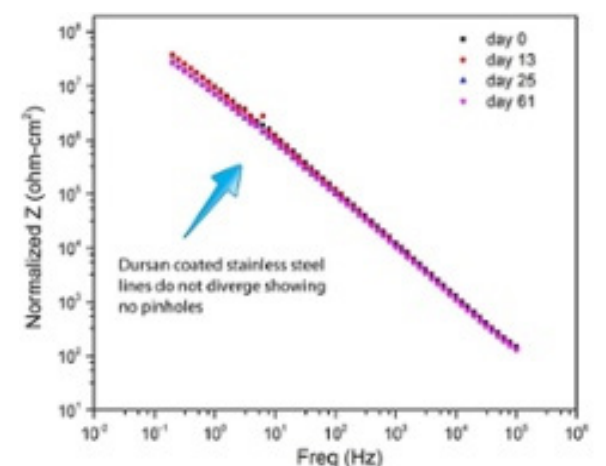

After 247 days, Dursan continues to be pinhole free and corrosion resistant.

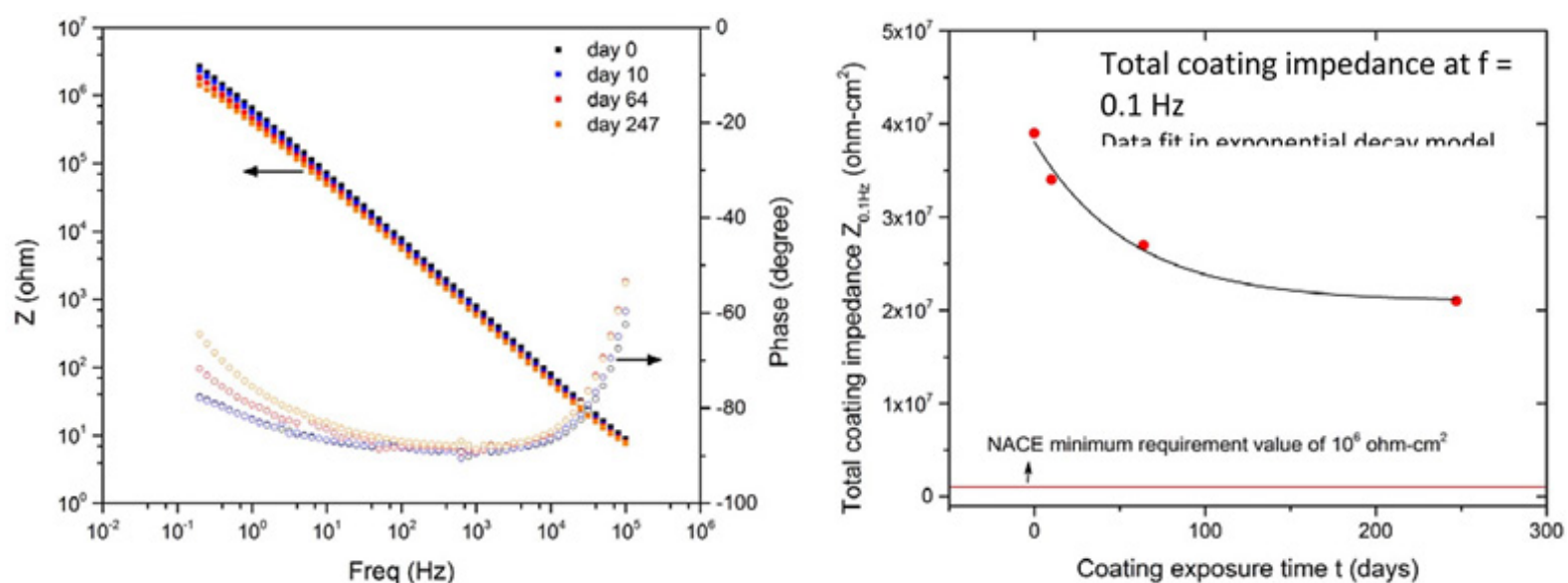

Already got rust? Learn how to get rid of it.

So what is the most effective way to remove surface rust from stainless steel?

The best method will effectively remove surface rust, but minimize impact to the bulk stainless steel substrate. Two methods used by SilcoTek® to remove surface rust employ weak acids.

Phosphoric Acid

Soaking a part in phosphoric acid will dissolve iron oxide without attacking the other components of the steel (chromium and chromium oxide, nickel, and iron).

Acetic Acid

The reaction with acetic acid is often slower than phosphoric acid and can be a better choice when the underlying corrosion/staining affects a larger percentage of the substrate.

[Read the entire guide on How to Remove Rust](#)

After rust is removed from the surface, coat the parts with a corrosion resistant coating like [Dursan®](#) or [Silcolloy®](#) to prevent future flow path corrosion.

Once Rust is Gone, Keep it Off.

Once the rust is gone, use rugged silicon-based coatings from SilcoTek to improve the corrosion resistance of stainless steel and other alloys. Read more about [corrosion resistant coating solutions](#) and how they can benefit you.

Process analyzers and process sampling systems can be exposed to challenging corrosive environments both internally and externally. Many sample streams contain reactive compounds that reduce equipment lifetime or require extended preventative maintenance. Some systems are exposed to environments such as sea water and salt spray, which cause rapid deterioration of equipment, requiring extra cost to keep them operating. Or, the sample stream itself can be highly corrosive like those found in stack or flare systems. For systems that are required to give accurate, reliable and repeatable data in such conditions, the cost of upkeep and maintenance can be excessive in both dollars and lost yield or productivity due to plant or system outages. That's why it's important to find ways to improve the corrosion resistance of components rather than just constantly removing rust from surfaces, or worse - paying for frequent replacements.

6. Conclusion

SilcoTek's silicon coatings applied by chemical vapor deposition (CVD) improve the inertness, corrosion resistance and durability of sample flow paths. Improving flow path performance can have a significant impact on quality of results and profitability. Here are a few examples:

- Go with a hydrophobic, water repelling surface to prevent corrosion and adsorption of analytes.
- Use inert coatings to act as a barrier between reactive stainless steel and the sample. An inert, silicon surface like SilcoNert® or Dursan® will not adsorb or react with sulfur samples.
- Line sample flow paths with these silicon coatings to also prevent loss of mercury and ammonia samples.
- Silicon coatings bonded to stainless steel flow paths prevent corrosion, reactivity, & oxidation in high temperature process, stack and flare sampling applications.
- Prevent flow path rust if you want to improve reliability of the sample data and system itself.

Inert coatings from can be a cost effective solution in many [industries and applications](#) including analytical/laboratory instrumentation and sampling, oil and gas upstream and downstream sampling, refinery/petrochemical, semiconductor and research, amongst many more.

Go to our [coating selection guide](#) to get the right coating solution for your application. Or [contact our technical service staff](#), and we'll be happy to discuss your application in detail.

Received this e-book from a colleague but want to make sure you get the rest of the series? [Click here to subscribe](#).

Start Improving Process Sampling Now

You've read the e-book, now it's time to take action! Contact our technical service team so we can help you select the best coating and evaluation methods for your application. We'll even send you free coated samples for you to put to the test. Click the link below to get started!

Contact our Technical
Service Team